



TARPING SYSTEMS & ACCESSORIES

P/N 1126870 Rev. A

OPERATING INSTRUCTIONS



Wireless Remote

READ BEFORE INSTALLING

PO BOX 713 ■ 2309 SHUR-LOK STREET ■ YANKTON, SD 57078-0713
PHONE 1-800-4-SHUR-LOK (1-800-474-8756) ■ FAX 605-665-0501
www.shurco.com

SHOP ONLINE: www.shopshurco.com

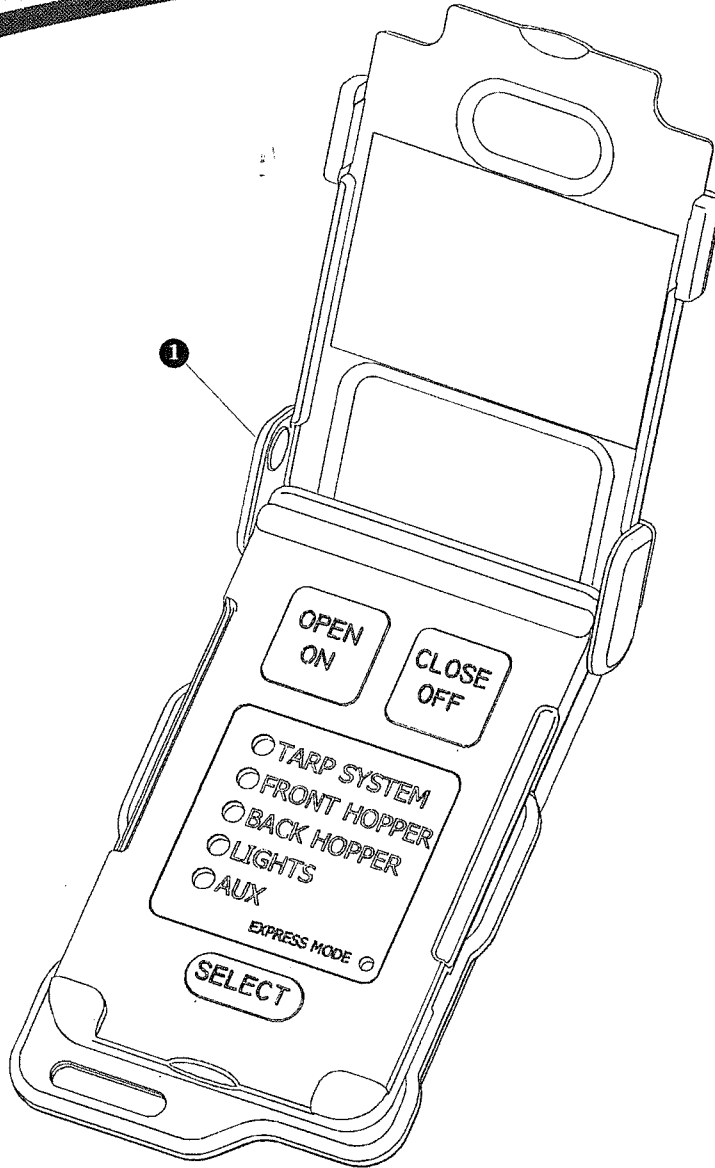

- TARP 1
- TARP 2
- TURNING PT. BOW
- LIGHT 1/2
- LIGHT 1
- LIGHT 2
- GATE
- HOIST UP | DOWN
- HOPPER 1
- HOPPER 2
- HOPPER 3



- AUGER LEFT | RIGHT
- AUGER UP | DOWN
- AUGER FOLD | UNFOLD
- DOOR
- BELT 1
- BELT 2
- AXLE UP | DOWN

Item	Part #	Description
1.	1126867	SMART3™ Replacement Transmitter
2.	1705940	SMART3™ Operation Labels

⚠ NOTICE

Do not power SMART3™ or any Shur-Co® wire-less system with battery charger alone, as this will likely cause system abnormalities and/or system malfunction. Instead, use 12-volt truck/automobile battery to provide power to trailer.

POWER UP/DOWN

Transmitter (remote) will power up when lid is opened. Remote will power down when lid is closed or left open three minutes after last button is pushed.

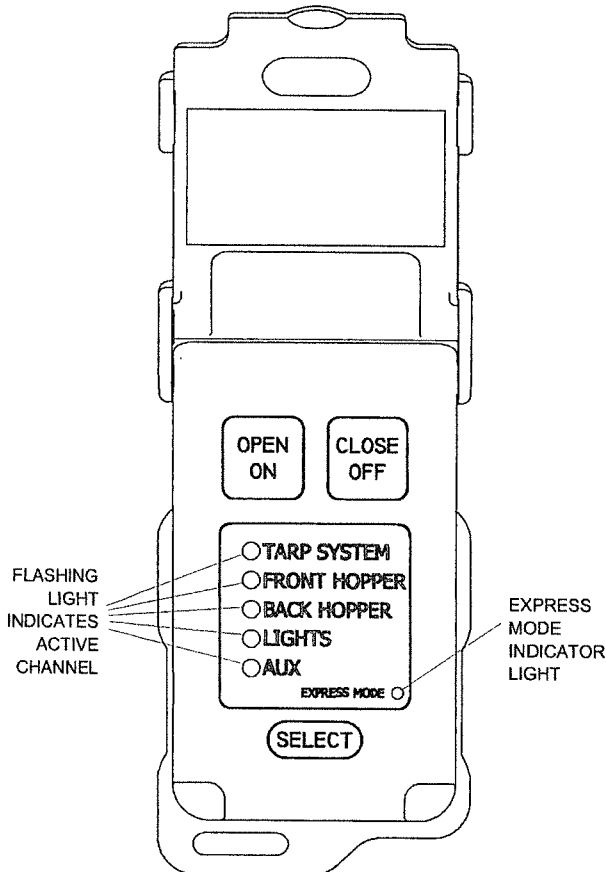

STANDARD OPERATION

After power-up, first channel will be immediately active and indicator light will be flashing. *Open/On* and *Close/Off* buttons are operational for indicated active channel. While either *Open* or *Close* button is pressed, indicator light for active channel will flash faster, indicating command is being transmitted on active channel. *Select* button will cycle between enabled channels.

If light does not flash more quickly when a command button is held, then remote has not connected to receiver. Receiver may not be nearby, may not be powered up or may not be paired to receiver.

Each channel on remote can be set to operate in either *Momentary Mode* or *Express Mode*.

NOTE: Remote ships from factory with first channel (TARP) configured to **EXPRESS MODE**. Other four channels are configured to **MANUAL MODE**.

NOTE: See **CHANNEL CONFIGURATION** section for instructions on how to set operating mode for each channel.

NOTE: Even if remote channel is configured to **EXPRESS MODE**, system will not operate in **EXPRESS MODE** unless encoder wires between motor and control box are connected.

NOTE: Some Shur-Co® products are not compatible with **EXPRESS MODE**. If motor does not have encoder wire or other feedback, system will operate in **MOMENTARY MODE** only.

NOTE: If your system is not compatible with **EXPRESS MODE**, disable **EXPRESS MODE** for that channel to avoid confusion.

Momentary Mode: While remote channel is in *Momentary Mode*, *Open* or *Close* button must be held down to operate system.

Indicator light labeled *Express Mode* will be off when remote is in *Momentary Mode*.

If remote channel is in *Momentary Mode*, you may still force system to open or close automatically one time by pressing *Open* or *Close*, while pressing *Select* button. System will continue to operate until fully open or closed. System can be stopped at any time by pressing any button on remote or closing remote lid.

Indicator light labeled **EXPRESS MODE** will be lit while system is operating in that mode.

Express Mode: While remote channel is in *Express Mode*, *Open* or *Close* button can be pressed and released. System will continue to operate until fully open or closed. System can be stopped at any time by pressing any button on remote or closing remote lid.

Indicator light labeled *Express Mode* will be on when remote is in that mode.

NOTE: 4500 HD Tarp systems operate in **EXPRESS MODE** when commanded to operate from buttons on trailer-mounted control box. Closing remote lid or pressing **SELECT** button will not stop system in this case. Pressing **OPEN** or **CLOSE** button on remote will stop system if in range.

PAIRING (INTRODUCING) REMOTE(S) TO RECEIVER

Receiver will accept and respond to signals from up to three remotes. Receiver will not respond to signals from remotes that have not been paired to it.

NOTE: Remotes are typically paired to receivers at factory if remote is shipped with receiver.

NOTE: Only SMART3™ remotes will function with SMART3™ receivers. The original SMARTtransmitter® or SMART1+™ cannot be used.

STEP 1: Connect receiver to power. Make sure target receiver is connected to 12-volt power supply. Keep remote within 20' of receiver during pairing process.

STEP 2: Prepare remote. Open remote lid and use Select button to select desired channel on remote. Set remote aside, but do not close lid.

SELECT BUTTON

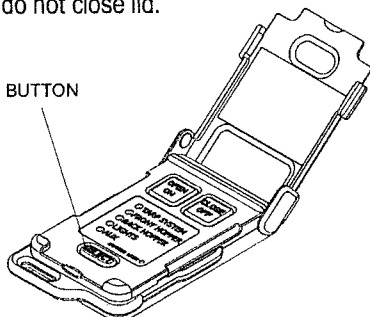

STEP 3: Put receiver into pair mode.

Option 1: On receiver, press and hold simultaneously both Open and Close buttons on receiver. After three seconds, you will hear buzzer beep. Release buttons. Receiver is now in pair mode.

OPEN BUTTON CLOSE BUTTON

OPEN BUTTON CLOSE BUTTON

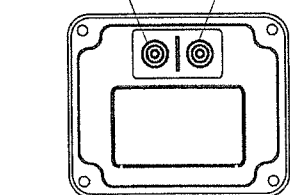

MINI-MODULE

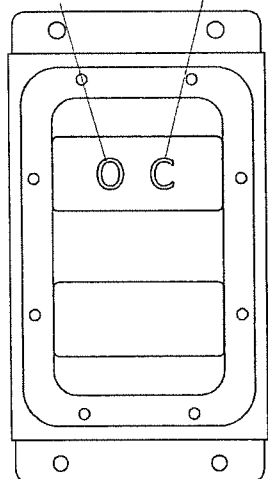

RECEIVER

Option 2: Standard receiver boxes only: Remove eight screws holding plastic cover on receiver box. Pull cover off gently, but do not disconnect any wires. Press and hold programming button next to red light. Red light will go solid. After three seconds, light will start blinking and buzzer will beep. Release button. Receiver is now in Pair Mode.

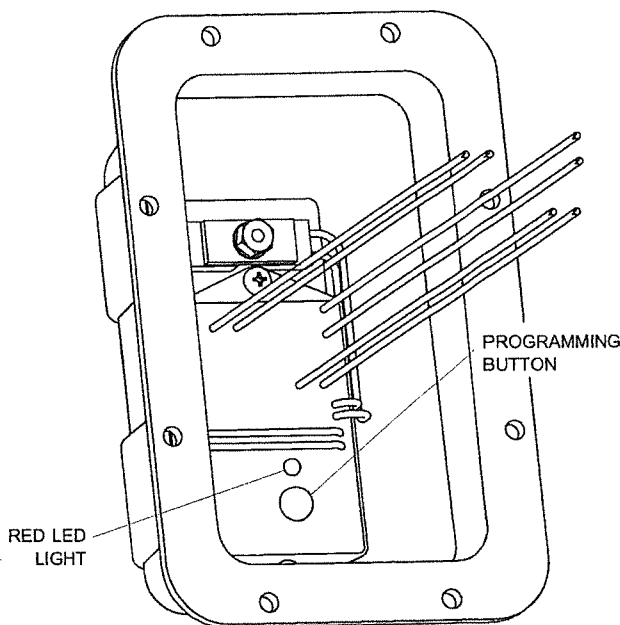

STEP 4: Put remote into pair mode. Pick up remote and press and hold simultaneously both OPEN and CLOSE buttons on remote. After three seconds, channel indicator light will go solid. Release buttons.

STEP 5: Complete pairing. Remote will now pair to receiver. If pairing was successful, receiver buzzer will beep twice. Remote can now be used to control receiver. If pairing was unsuccessful, receiver will time out of Pair Mode after 15 seconds and buzzer will beep once. Try again to pair.

STEP 6: Repeat process for any other remotes.

NOTE: When you press OPEN and CLOSE on receiver, you may hear a click from solenoid in receiver box, but outputs will not stay on while both buttons are held simultaneously.

NOTE: While in PAIR MODE, receiver will not turn outputs on.

CONFIGURING REMOTE CHANNELS

Shur-Co® SMART3™ remote has five channels for controlling up to five different devices. Channels can be configured as follows:

- Unused channels can be disabled to be skipped when *Select* button is pressed.
 - Operating mode of each channel can be set to *Momentary Mode* or *Express Mode*.
1. Hold *Select* button down for five seconds and remote will enter *Channel Configuration Mode*. LED of first channel will be lit solid on remote. This indicates first channel is ready to be configured.
 2. Set operating mode of channel. If *Express Mode* indicator light is lit solid, then channel will operate in *Express Mode*. If *Express Mode* indicator light is not on, channel will operate in *Momentary Mode*. Press *Select* button to toggle operating mode to desired setting.
 3. Enable or disable channel. If channel will be used and paired with receiver, press *Open/On* button. If channel will not be used, channel can be disabled by pressing *Close/Off* button. Indicator light will automatically jump to next channel.

NOTE: Remote will NOT activate any motor or lighting system while remote is in **CHANNEL CONFIGURATION MODE**.

4. Repeat steps 2 and 3 for remaining channels.
5. After configuring last channel, channel status for all channels will be displayed for three seconds. Channel indicator lights of enabled channels will be lit solid and channel indicator lights of disabled channels will be off. Remote will then automatically return to *Operational Mode*.

TIP: To cancel changes and exit **CHANNEL CONFIGURATION MODE**, close remote cover.

LOW BATTERY INDICATION

If battery level is getting low, all lights on remote will flash for three seconds when lid is opened and operation is attempted. Remote will then operate normally.

If battery level drops lower, remote will automatically turn off after flashing indication and batteries must be replaced.

REPLACING BATTERIES

The SMART3™ remote uses two AAA batteries. To access batteries, unfasten center screw shown below and gently lift cover tab.

TO ACCESS BATTERY,
UNFASTEN SCREW ON
BACK OF REMOTE WITH
PHILLIPS SCREWDRIVER

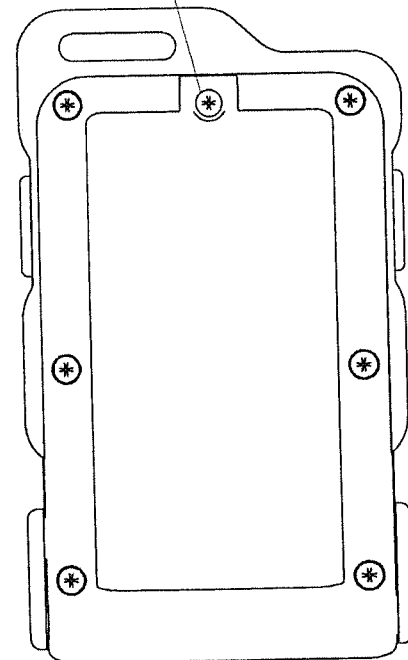

Our **Advanced Troubleshooting Guide** is available on our website: <http://www.shurco.com>, or call our Help Line: 1-866-748-7435.

PROBLEM:	TRY THIS:
<p>SMART3™ remote is not working. No LED lights on remote are on.</p>	<ol style="list-style-type: none"> 1. Close lid and open it again. 2. Make sure batteries are placed correctly. 3. Replace both AAA batteries in remote. 4. Remote may be damaged. Call Shur-Co's Help Line.
<p>All lights flash for three seconds, remote turns off.</p>	<ol style="list-style-type: none"> 1. Batteries are too low and must be replaced.
<p>SMART3™ remote is not working. I can operate system with buttons on trailer mounted receiver box, but not with remote. Remote channel light (next to <i>Tarp System</i>, for example) is blinking, and when I press <i>Open/On</i> button, light blinks faster.</p>	<ol style="list-style-type: none"> 1. Make sure remote is set to right channel. If you cannot set remote to desired channel (<i>Tarp System</i>, for example) by pressing <i>Select</i> button, channel must be enabled. See Channel Enable/Disable section and enable channel. 2. Reprogram remote to receiver and try again. See Remote to Receiver Programming section. 4. Call Shur-Co's Help Line.
<p>System will not operate with the remote or with the buttons on the trailer-mounted receiver. When the <i>Open</i> or <i>Close</i> button is pressed, I don't hear a loud click from the receiver box.</p>	<ol style="list-style-type: none"> 1. Make sure master disconnect switch on trailer (if equipped) is turned to <i>On</i> position. 2. Circuit breaker may have tripped. Wait 15 seconds and try again. 3. Check for loose or corroded connections between battery and solenoid in receiver box. 4. Check for low system voltage. Measure voltage between positive and negative posts on solenoid in receiver box on trailer. Positive solenoid post is marked "+" and negative post is marked "-" at base of posts. With truck off, voltage should measure between 12.5 and 12.7 volts. Make sure voltage reading is not negative, which indicates power wires are hooked up backwards.
<p>System will not operate with remote or with buttons on trailer-mounted receiver. When <i>Open</i> or <i>Close</i> button is pressed, solenoid in receiver box will click loudly (or "chatter"), but motor does not turn.</p>	<ol style="list-style-type: none"> 1. Bypass circuit breaker in battery box and try again. If problem goes away, breaker was fatigued or corroded and should be replaced. 2. Ensure battery connections are tight and free of corrosion. Inspect all wires between batteries for corrosion. Verify battery voltage is between 12.5 and 12.7 volts with truck off. Be sure to measure voltage on battery to which system is connected. 3. Inspect dual-pole power connection at front of trailer. Replace if corrosion is present. Disassemble connector to inspect set screws inside and make sure they are tight, free of corrosion, and that none of wire strands are short-circuiting. Apply dielectric grease (not black grease) to metal contacts. 4. Inspect wiring between dual-pole connector at front of trailer and solenoid in receiver box. Replace corroded wires. Check wire for cuts in insulation. Copper wire will corrode quickly if insulation is cut. 5. Disconnect motor from back two posts (marked <i>In</i> and <i>Out</i>) on solenoid. Press and hold <i>Open</i> or <i>Close</i> button to engage solenoid. If solenoid does not measure at least 12.5 or -12.5 volts between back two posts while engaged, solenoid is damaged. Call Shur-Co's Help Line. 6. If solenoid voltage measures at least 12.5 or -12.5 volts between back two posts (marked <i>In</i> and <i>Out</i>) when motor wire is disconnected, motor may be damaged or there may be a short circuit in motor wire between motor and solenoid. This assumes system has been checked for corrosion and other issues listed above. Call Shur-Co's Help Line.

PROBLEM:	TRY THIS:
System will not run in <i>Express Mode</i>	<ol style="list-style-type: none"> 1. Check all encoder wires between motor and receiver for cuts. Make sure connectors are connected tightly. Make sure the black encoder wire is always connected to another black encoder wire at connectors. On 4500 HD tarping systems, make sure sealed weatherpack connectors are snap-locked together. There is one weatherpack connector near the motor and one in the kingpin area. 2. Call Shur-Co's Help Line.

NOTE: To quickly determine if problem lies with wiring between battery and solenoid, disconnect power from truck and hook jumper cables from vehicle directly to solenoid. Hook positive battery cable to solenoid positive post (marked +). Hook negative battery cable to solenoid negative post (marked -). If system runs normally, problem is with wiring supplying power to solenoid.

RADIO & TELEVISION INTERFERENCE

Changes or modifications not expressly approved by party responsible for compliance could void user's authority to operate equipment.

NOTE: Equipment has been tested and found to comply with limits for Class B digital devices, pursuant to part 15 of FCC Rules. Limits are designed to provide reasonable protection against harmful interference in residential installation. This equipment generates, uses and can radiate radio frequency energy and, if not installed and used in accordance with instructions, may cause harmful interference to radio communications. However, there is no guarantee interference will not occur in a particular installation. If equipment does cause harmful interference to radio or television reception, which can be determined by turning equipment off and on, user is encouraged to try to correct interference by one or more following measures:

- Reorient or relocate receiving antenna.
- Increase separation between equipment and receiver.
- Connect equipment into outlet on different circuit.
- Consult dealer or experienced radio/TV technician for help.

Son fonctionnement est soumis aux deux conditions suivantes:
 (1) cet appareil ne peut pas provoquer d'interférences, et (2)
 cet appareil doit accepter toute interférence, y compris celles
 susceptibles de provoquer le fonctionnement du dispositif.